

# KAMAMI

## KAmoDGYRO



Rev. 20241101164604

Źródło: <https://wiki.kamamilabs.com/index.php?title=KAmoDGYRO>

## Table of contents

Basic parameters .....	1
Standard equipment .....	2
Electrical schematic .....	3
View of board .....	4
SPI connector .....	5
I2C connector .....	6

## Description

[KAmoGYRO](#) is a 3-axis gyroscope with SPI i I2C interfaces. The module is based on L3G4200D chip from STMicroelectronics. It allows to make a measurement of angle velocity in every of three axis.



## Basic parameters

- 3-axis gyroscope L3G4200D
- Power supply voltage 2.4V-3.6V
- SPI and I2C interfaces (connectors compatible with Kamami standard)
- Output data in resolution 16 bit
- Three measurement ranges to choose (250, 500, 2000 dps)
- High stability against time and temperature
- Embedded temperature sensor
- Embedded low- and highpass filters
- High shock resistance

## Standard equipment

Code	Description
<b>KAmoGYRO</b>	• Assembled module board

## Electrical schematic

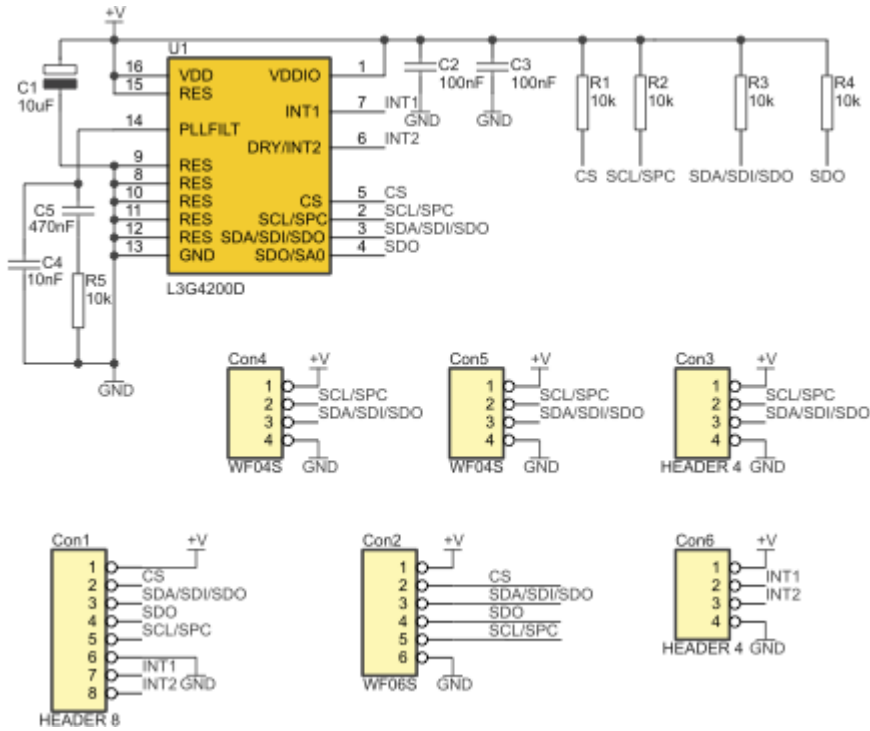

## View of board

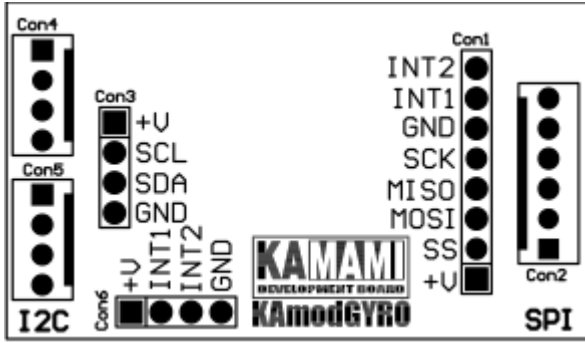

## SPI connector

Con2 connector is a SPI connector in Kamami standard (compatible with i.a. ZL15AVR, ZL30ARM, cable CAB\_HU06). SPI interface is also available on Con1 connector. On Con1 are interrupt outputs pins of L3G4200D (INT1 i INT2) additional available.

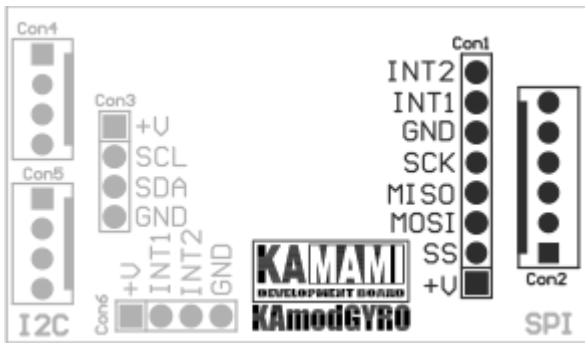

## I2C connector

KAmoGYRO module is equipped with I2C interface on Con3, Con4 and Con5 connectors. Location of lines on Con4 and Con5 connectors are compatible with Kamami standard (i.a. z ZL15AVR, ZL30ARM, cable CAB\_HU04). By using I2C interface can be used Con6 connector with interrupt generator outputs.

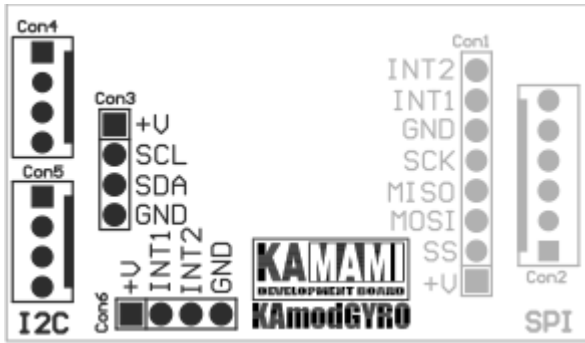





Zastrzegamy prawo do wprowadzania zmian bez uprzedzenia.

Oferowane przez nas płytki drukowane mogą się różnić od prezentowanej w dokumentacji, przy czym zmianom nie ulegają jej właściwości użytkowe.

BTC Korporacja gwarantuje zgodność produktu ze specyfikacją.

BTC Korporacja nie ponosi odpowiedzialności za jakiegokolwiek szkody powstałe bezpośrednio lub pośrednio w wyniku użycia lub nieprawidłowego działania produktu.

BTC Korporacja zastrzega sobie prawo do modyfikacji niniejszej dokumentacji bez uprzedzenia.